

Accredited (Indicative) Detail Number: SFW-GF-01

**GENERAL NOTES**

- If sole plates are packed to level ensure that a continuous mortar grout is installed.
- The wall insulation installed below the wall DPC must be fit for purpose with regards to water absorption.
- If compressible insulation is installed between the studs in addition to the rigid board insulation over, then it should be tightly packed and be in direct contact with the rigid board. Care must be taken to ensure that the compressible insulation is maintained above the dewpoint temperature.
- A degree of thermal bridging is inevitable in this location since robust bearing and holding down arrangements are normally required between the frame and slab. Appropriate design should keep this thermal bridging within acceptable limits to reduce the risk of condensation.

The above indicative guidance illustrates good practice for the design and construction of interfaces only in respect to ensuring thermal performance and air barrier continuity. The above guidance must be implemented with due regard to all other requirements imposed by the Building Regulations.

CHECKLIST (TICK)

**THERMAL PERFORMANCE OF JUNCTION**

- Ensure wall insulation is installed at least 200mm below the top of floor insulation.
- Floor insulation must tightly abut the inner face of the upstand or steel frame. ①
- If screed is used instead of timber floor covering then edge insulation having a minimum R-value of 0.75m<sup>2</sup>K/W should be installed through the depth of the screed.
- Any upstand installed to the edge of the floor to support the steel framing must be formed with insulating blocks.

*Complying with the above checklist items qualifies the builder to claim the  $\Psi$  value given in Table 3 of IP 1/06 and Table K1 of SAP 2005.*

CHECKLIST (TICK)

**AIR BARRIER CONTINUITY**

- Ensure air barrier continuity between the floor and the wall lining or sheathing layer. A flexible membrane installed below the steel channel may be used to provide this continuity.
- Seal between the wall and floor air barrier with a flexible sealant ② **OR** seal the gap between the skirting board and the floor using a flexible sealant. ③
- Seal all penetrations through air barrier using a flexible sealant or tape.

*Complying with all of the above checklist items will help achieve the design air permeability and may effect a reduced testing regime.*

OPTION (TICK)

**AIR BARRIER OPTIONS**

- Rigid insulation or board sheathing, or
- Internal lining (e.g. plasterboard)

| SITE MANAGER/ SUPERVISOR: | SITE NAME: | PLOT No: | DATE: |
|---------------------------|------------|----------|-------|
|                           |            |          |       |

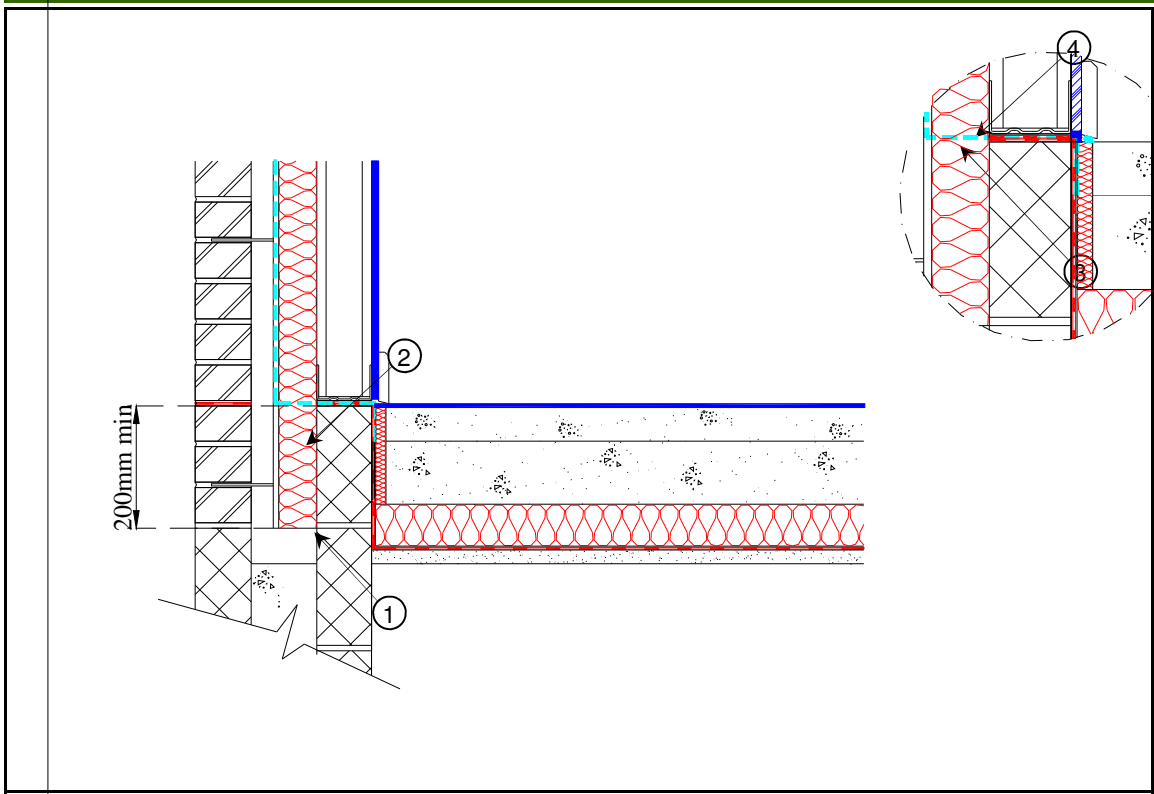

Accredited (Indicative) Detail Number: SFW-GF-02

**GENERAL NOTES**

- If compressible insulation is installed between the studs in addition to the rigid board insulation over, then it should be tightly packed and be in direct contact with the rigid board. Care must be taken to ensure that the compressible insulation is maintained above the dewpoint temperature.
- The wall insulation installed below the wall DPC must be fit for purpose with regards to water absorption.
- A degree of thermal bridging is inevitable in this location since robust bearing and holding down arrangements are normally required between the frame and slab. Appropriate design should keep this thermal bridging within acceptable limits to reduce the risk of condensation.

The above indicative guidance illustrates good practice for the design and construction of interfaces only in respect to ensuring thermal performance and air barrier continuity. The above guidance must be implemented with due regard to all other requirements imposed by the Building Regulations.

CHECKLIST (TICK)

**THERMAL PERFORMANCE OF JUNCTION**

- Ensure wall insulation is installed at least 200mm below the top of floor insulation.
- Floor insulation must tightly abut the inner face of the upstand or steel frame. ①
- If screed is used instead of timber floor covering then edge insulation having a minimum R-value of 0.75m<sup>2</sup>K/W should be installed through the depth of the screed. ②

*Complying with the above checklist items qualifies the builder to claim the  $\Psi$  value given in Table 3 of IP 1/06 and Table K1 of SAP 2005.*

CHECKLIST (TICK)

**AIR BARRIER CONTINUITY**

- Ensure air barrier continuity between the floor and the wall lining or sheathing layer. A flexible membrane installed below the steel channel may be used to provide this continuity.
- Seal between the wall and floor air barrier with a flexible sealant ③ **OR** seal the gap between the skirting board and the floor using a flexible sealant. ④
- Seal all penetrations through air barrier using a flexible sealant or tape.

*Complying with all of the above checklist items will help achieve the design air permeability and may effect a reduced testing regime.*

OPTION (TICK)

**AIR BARRIER OPTIONS**

- Rigid insulation or board sheathing, or
- Internal lining (e.g. plasterboard)

| SITE MANAGER/ SUPERVISOR: | SITE NAME: | PLOT No: | DATE: |
|---------------------------|------------|----------|-------|
|                           |            |          |       |

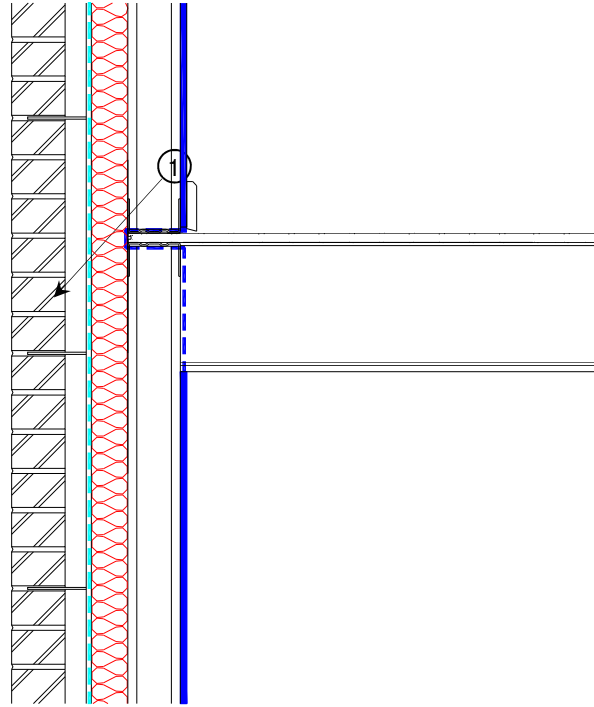

Accredited (Indicative) Detail Number: SFW-IF-01

**GENERAL NOTES**

- If compressible insulation is installed between the studs in addition to the rigid board insulation over, then it should be tightly packed and be in direct contact with the rigid board. Care must be taken to ensure that the compressible insulation is maintained above the dewpoint temperature.

The above indicative guidance illustrates good practice for the design and construction of interfaces only in respect to ensuring thermal performance and air barrier continuity. The above guidance must be implemented with due regard to all other requirements imposed by the Building Regulations.

CHECKLIST (TICK)

**THERMAL PERFORMANCE OF JUNCTION**

Continue wall insulation across the floor abutment zone.

*Complying with the above checklist items qualifies the builder to claim the  $\Psi$  value given in Table 3 of IP 1/06 and Table K1 of SAP 2005.*

CHECKLIST (TICK)

**AIR BARRIER CONTINUITY**

If using the wall lining to form the air barrier, ensure air barrier continuity between the upper and lower wall linings. A flexible membrane installed around the floor edge may be used to provide this continuity. ① (The dotted blue line depicts the continuity of the air barrier through the floor zone)

Seal all penetrations through air barrier using a flexible sealant or tape.

*Complying with all of the above checklist items will help achieve the design air permeability and may effect a reduced testing regime.*

OPTION (TICK)

**AIR BARRIER OPTIONS**

Rigid insulation or board sheathing, or

Internal lining (e.g. plasterboard)

| SITE MANAGER/ SUPERVISOR: | SITE NAME: | PLOT No: | DATE: |
|---------------------------|------------|----------|-------|
|                           |            |          |       |

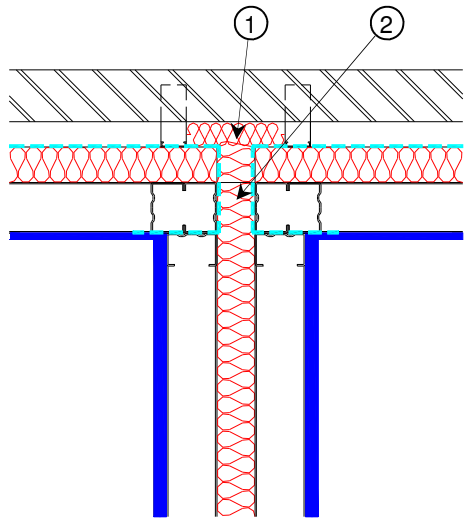

Accredited (Indicative) Detail Number: SFW-IW-01

**GENERAL NOTES**

- If compressible insulation is installed between the studs in addition to the rigid board insulation over, then it should be tightly packed and be in direct contact with the rigid board. Care must be taken to ensure that the compressible insulation is maintained above the dewpoint temperature.
- Refer to Approved Document B for fire safety requirements and to Approved Document E for sound insulation requirements.
- This detail to be read in conjunction with detail No: SFW-IW-02.

The above indicative guidance illustrates good practice for the design and construction of interfaces only in respect to ensuring thermal performance and air barrier continuity. The above guidance must be implemented with due regard to all other requirements imposed by the Building Regulations.

CHECKLIST (TICK)

**THERMAL PERFORMANCE OF JUNCTION**

- Continue external wall insulation across the abutment zone. ①
- Ensure continuity of insulation between the separating wall and external wall construction. ②

*Complying with the above checklist items qualifies the builder to claim the  $\Psi$  value given in Table 3 of IP 1/06 and Table K1 of SAP 2005.*

CHECKLIST (TICK)

**AIR BARRIER CONTINUITY**

- Ensure air barrier continuity between the sheathing layer and the wall lining or sheathing layer. A flexible membrane installed around the steel channels may be used to provide this continuity.
- Seal all penetrations through air barrier using a flexible sealant or tape.

*Complying with all of the above checklist items will help achieve the design air permeability and may effect a reduced testing regime.*

OPTION (TICK)

**AIR BARRIER OPTIONS**

- Rigid insulation or board sheathing, or
- Internal lining (e.g. plasterboard)

| SITE MANAGER/ SUPERVISOR: | SITE NAME: | PLOT No: | DATE: |
|---------------------------|------------|----------|-------|
|                           |            |          |       |

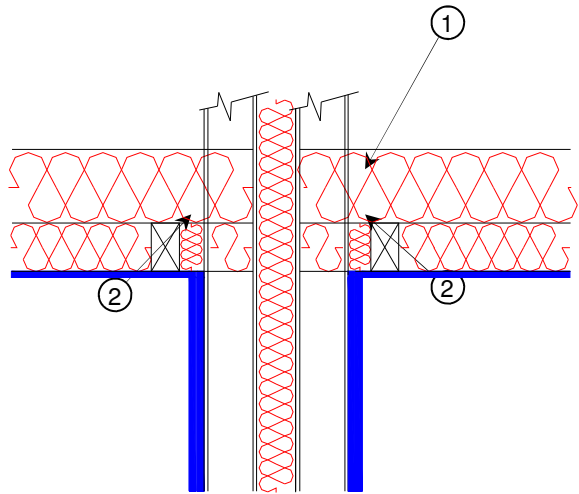

Accredited (Indicative) Detail Number: SFW-IW-02

**GENERAL NOTES**

- If compressible insulation is installed between the studs in addition to the rigid board insulation over, then it should be tightly packed and be in direct contact with the rigid board. Care must be taken to ensure that the compressible insulation is maintained above the dewpoint temperature.
- Refer to Approved Document B for fire safety requirements and to Approved Document E for sound insulation requirements.
- This detail to be read in conjunction with detail No: SFW-IW-01.

The above indicative guidance illustrates good practice for the design and construction of interfaces only in respect to ensuring thermal performance and air barrier continuity. The above guidance must be implemented with due regard to all other requirements imposed by the Building Regulations.

CHECKLIST (TICK)

**THERMAL PERFORMANCE OF JUNCTION**

- Pack compressible insulation between last truss/ joist and separating wall. ①
- Ensure that the full depth of insulation between, over (or below) the joists extends through the stud framework.

*Complying with the above checklist items qualifies the builder to claim the  $\Psi$  value given in Table 3 of IP 1/06 and Table K1 of SAP 2005.*

CHECKLIST (TICK)

**AIR BARRIER CONTINUITY**

- Seal between wall and ceiling lining. ②
- Seal all penetrations through air barrier using a flexible sealant or tape.

*Complying with all of the above checklist items will help achieve the design air permeability and may effect a reduced testing regime.*

OPTION (TICK)

**AIR BARRIER OPTIONS**

- Internal lining (e.g. plasterboard)

| SITE MANAGER/ SUPERVISOR: | SITE NAME: | PLOT No: | DATE: |
|---------------------------|------------|----------|-------|
|                           |            |          |       |

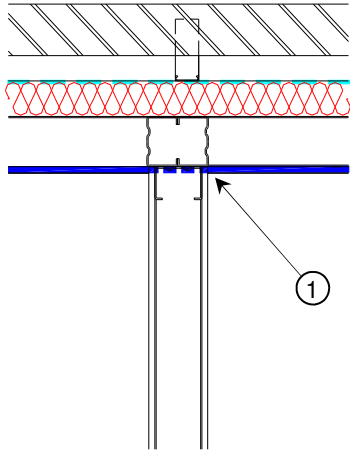

Accredited (Indicative) Detail Number: SFW-IW-03

**GENERAL NOTES**

- If compressible insulation is installed between the studs in addition to the rigid board insulation over, then it should be tightly packed and be in direct contact with the rigid board. Care must be taken to ensure that the compressible insulation is maintained above the dewpoint temperature.
- This detail to be read in conjunction with detail No: SFW-IW-04.

The above indicative guidance illustrates good practice for the design and construction of interfaces only in respect to ensuring thermal performance and air barrier continuity. The above guidance must be implemented with due regard to all other requirements imposed by the Building Regulations.

CHECKLIST (TICK)

**THERMAL PERFORMANCE OF JUNCTION**

Continue wall insulation across the abutment zone.

*Complying with the above checklist items qualifies the builder to claim the  $\Psi$  value given in Table 3 of IP 1/06 and Table K1 of SAP 2005.*

CHECKLIST (TICK)

**AIR BARRIER CONTINUITY**

If using the wall lining ensure continuity of the air barrier across the partition wall. Tape seal over any open holes in the end vertical partition channel. ① (The dotted blue line depicts the continuity of the air barrier through the partition stud member)

Fully seal all penetrations through air barrier using a flexible sealant.

*Complying with all of the above checklist items will help achieve the design air permeability and may effect a reduced testing regime.*

OPTION (TICK)

**AIR BARRIER OPTIONS**

Rigid insulation or board sheathing, or

Internal lining (e.g. plasterboard)

| SITE MANAGER/ SUPERVISOR: | SITE NAME: | PLOT No: | DATE: |
|---------------------------|------------|----------|-------|
|                           |            |          |       |

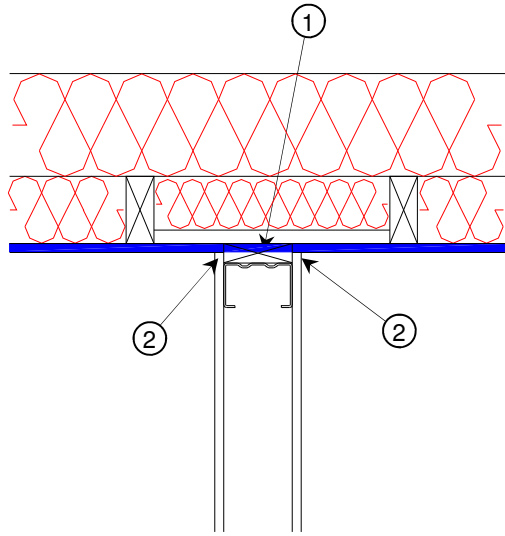

Accredited (Indicative) Detail Number: SFW-IW-04

**GENERAL NOTES**

- If compressible insulation is installed between the studs in addition to the rigid board insulation over, then it should be tightly packed and be in direct contact with the rigid board. Care must be taken to ensure that the compressible insulation is maintained above the dewpoint temperature.
- This detail to be read in conjunction with detail No: SFW-IW-03.

The above indicative guidance illustrates good practice for the design and construction of interfaces only in respect to ensuring thermal performance and air barrier continuity. The above guidance must be implemented with due regard to all other requirements imposed by the Building Regulations.

CHECKLIST (TICK)

**THERMAL PERFORMANCE OF JUNCTION**

Ensure that the full depth of insulation between and over the joists extends over the head of the wall.

*Complying with the above checklist items qualifies the builder to claim the  $\Psi$  value given in Table 3 of IP 1/06 and Table K1 of SAP 2005.*

CHECKLIST (TICK)

**AIR BARRIER CONTINUITY**

Fix timber head plate to underside of joists to receive metal channel. ①

Fix ceiling first and seal all gaps between the ceiling and timber head plate with flexible sealant prior to installing partition linings. ② (The dotted blue line depicts the continuity of the air barrier through the partition head plate)

Seal all penetrations through air barrier using a flexible sealant or tape.

*Complying with all of the above checklist items will help achieve the design air permeability and may effect a reduced testing regime.*

OPTION (TICK)

**AIR BARRIER OPTIONS**

Ceiling lining (e.g. plasterboard)

| SITE MANAGER/ SUPERVISOR: | SITE NAME: | PLOT No: | DATE: |
|---------------------------|------------|----------|-------|
|                           |            |          |       |

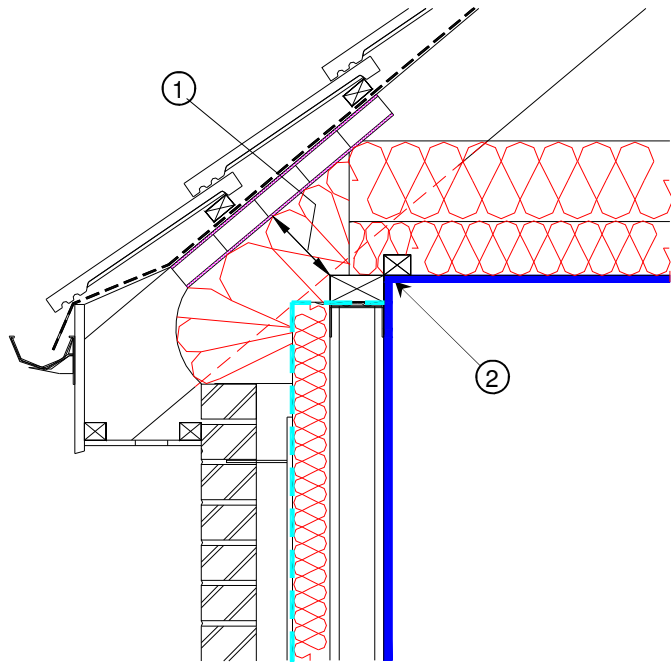

Accredited (Indicative) Detail Number: SFW-RE-01

**GENERAL NOTES**

- The use of over joist insulation is considered best practice as it eliminates the cold bridge caused by the joist.
- Use a proprietary eaves ventilator to ensure ventilation in accordance with BS5250.
- The installation of the eaves ventilator must not prevent free water drainage below the tiling battens.
- If compressible insulant is installed between the studs in addition to the rigid board insulant over, then it should be tightly packed and be in direct contact with the rigid board. Care must be taken to ensure that the compressible insulant is maintained above the dewpoint temperature.
- This detail to be read in conjunction with detail No: SFW-RG-01.

The above indicative guidance illustrates good practice for the design and construction of interfaces only in respect to ensuring thermal performance and air barrier continuity. The above guidance must be implemented with due regard to all other requirements imposed by the Building Regulations.

CHECKLIST (TICK)

**THERMAL PERFORMANCE OF JUNCTION**

Ensure the gap between the wall plate and the proprietary eaves ventilator is completely filled with insulation having a min. R-value across the thickness of the insulation of 1.2 m<sup>2</sup>.K/W. ①

Ensure continuity of the insulation throughout the junction.

Ensure that the full depth of insulation between and over the joists abuts the eaves insulation.

*Complying with the above checklist items qualifies the builder to claim the Ψ value given in Table 3 of IP 1/06 and Table K1 of SAP 2005.*

CHECKLIST (TICK)

**AIR BARRIER CONTINUITY**

Ensure air barrier continuity between the ceiling and the wall lining or sheathing layer. A flexible membrane installed below the wall plate may be used to provide this continuity. ②

Seal all penetrations through air barrier using a flexible sealant or tape.

*Complying with all of the above checklist items will help achieve the design air permeability and may effect a reduced testing regime.*

OPTION (TICK)

**AIR BARRIER OPTIONS**

Rigid insulation or board sheathing

Internal lining (e.g. plasterboard)

| SITE MANAGER/ SUPERVISOR: | SITE NAME: | PLOT No: | DATE: |
|---------------------------|------------|----------|-------|
|                           |            |          |       |

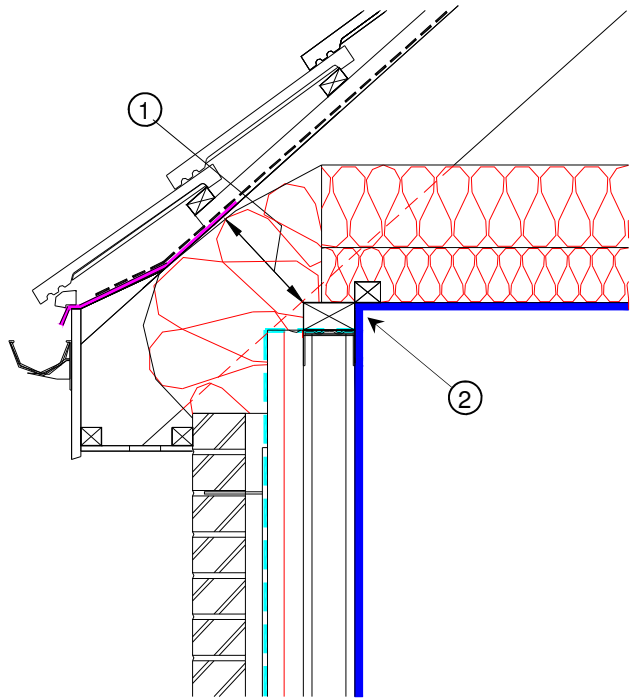

Accredited (Indicative) Detail Number: SFW-RE-02

**GENERAL NOTES**

- The use of over joist insulation is considered best practice as it eliminates the cold bridge caused by the joist.
- Vapour permeable roof underlay to be used in strict accordance with approved third party certification.
- The installation of the eaves insulation must not prevent free water drainage below the tiling battens.
- If compressible insulant is installed between the studs in addition to the rigid board insulant over, then it should be tightly packed and be in direct contact with the rigid board. Care must be taken to ensure that the compressible insulant is maintained above the dewpoint temperature.
- This detail to be read in conjunction with detail No: SFW-RE-02.

The above indicative guidance illustrates good practice for the design and construction of interfaces only in respect to ensuring thermal performance and air barrier continuity. The above guidance must be implemented with due regard to all other requirements imposed by the Building Regulations.

CHECKLIST (TICK)

**THERMAL PERFORMANCE OF JUNCTION**

- Ensure the gap between the wall plate and the proprietary eaves ventilator is completely filled with insulation having a min. R-value across the thickness of the insulation of 1.2 m<sup>2</sup>.K/W. ①
- Ensure continuity of the insulation throughout the junction.
- Ensure that the full depth of insulation between and over the joists abuts the eaves insulation.

*Complying with the above checklist items qualifies the builder to claim the  $\Psi$  value given in Table 3 of IP 1/06 and Table K1 of SAP 2005.*

CHECKLIST (TICK)

**AIR BARRIER CONTINUITY**

- Ensure air barrier continuity between the ceiling and the wall lining or sheathing layer. A flexible membrane installed below the wall plate may be used to provide this continuity. ②
- Seal all penetrations through air barrier using a flexible sealant or tape.

*Complying with all of the above checklist items will help achieve the design air permeability and may effect a reduced testing regime.*

OPTION (TICK)

**AIR BARRIER OPTIONS**

- Rigid insulation or board sheathing
- Internal lining (e.g. plasterboard)

| SITE MANAGER/ SUPERVISOR: | SITE NAME: | PLOT No: | DATE: |
|---------------------------|------------|----------|-------|
|                           |            |          |       |

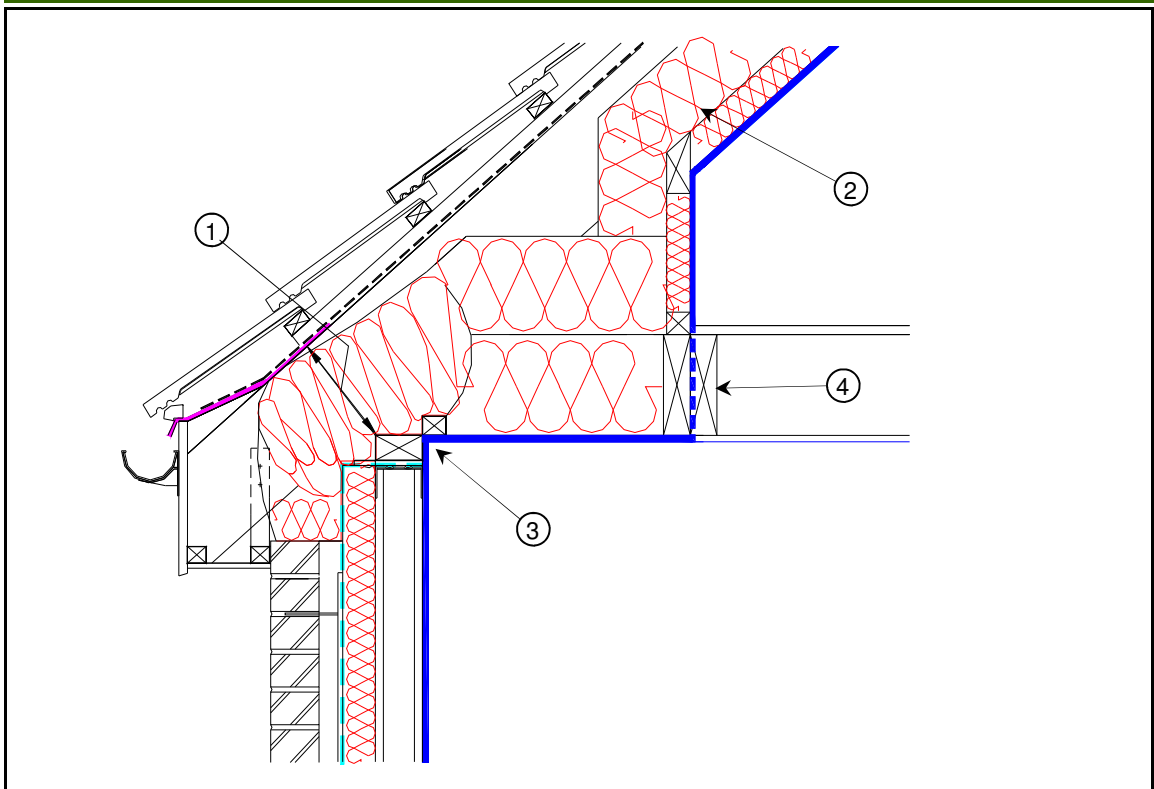

Accredited (Indicative) Detail Number: SFW-RE-03

**GENERAL NOTES**

- If required by BS5250 use a vapour control plasterboard or a separate vapour control layer behind the plasterboard.
- Vapour permeable roof underlay to be used in strict accordance with approved third party certification.
- The use of over joist and under rafter insulation is considered best practice as it eliminates the cold bridge caused by the joist/rafter..
- The installation of the eaves insulation must not prevent free water drainage below the tiling battens.
- If compressible insulant is installed between the studs in addition to the rigid board insulant over, then it should be tightly packed and be in direct contact with the rigid board. Care must be taken to ensure that the compressible insulant is maintained above the dewpoint temperature
- This detail to be read in conjunction with detail No: SFW-RG-02.

**SFW-RE-03 Pitched Roof. Between & Under Rafter Insulation. Unventilated Rafter Void. Eaves.**

CHECKLIST (TICK)

**THERMAL PERFORMANCE OF JUNCTION**

- Ensure the gap between the wall plate and the proprietary eaves guard is completely filled with insulation having a min. R-value across the thickness of the insulation of 1.2 m<sup>2</sup>.K/W. ①
- Ensure continuity of the insulation throughout the junction.
- Ensure that the full depth of insulation between and over the joists abuts the eaves insulation.
- Ensure that the insulation is installed tightly between the rafters and is in contact with the under rafter insulation. ②

*Complying with the above checklist items qualifies the builder to claim the  $\Psi$  value given in Table 3 of IP 1/06 and Table K1 of SAP 2005.*

CHECKLIST (TICK)

**AIR BARRIER CONTINUITY**

- Ensure air barrier continuity between the ceiling and the wall lining or sheathing layer. A flexible membrane installed below the wall plate may be used to provide this continuity. ③
- Seal all penetrations through air barrier using a flexible sealant or tape.
- Install a double, full depth timber nogging between the floor joists and seal between the nogging, ceiling and upper stud wall with a flexible sealant. ④ (The dotted blue line depicts the continuity of the air barrier through the noggings)

*Complying with all of the above checklist items will help achieve the design air permeability and may effect a reduced testing regime.*

OPTION (TICK)

**AIR BARRIER OPTIONS**

- Rigid insulation or board sheathing
- Internal lining (e.g. plasterboard)

The above indicative guidance illustrates good practice for the design and construction of interfaces only in respect to ensuring thermal performance and air barrier continuity. The above guidance must be implemented with due regard to all other requirements imposed by the Building Regulations.

| SITE MANAGER/ SUPERVISOR: | SITE NAME: | PLOT No: | DATE: |
|---------------------------|------------|----------|-------|
|                           |            |          |       |

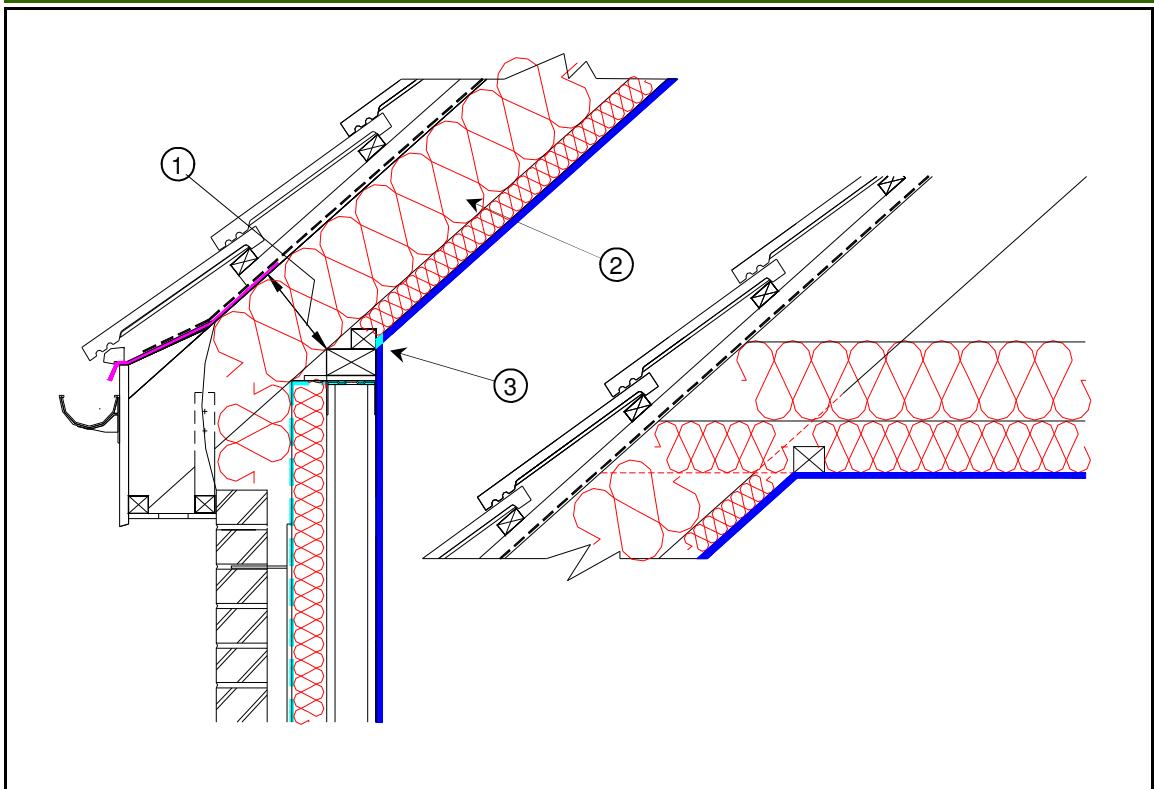

Accredited (Indicative) Detail Number: SFW-RE-04

**GENERAL NOTES**

- If required by BS5250 use a vapour control plasterboard or a separate vapour control layer behind the plasterboard.
- Vapour permeable roof underlay to be used in strict accordance with approved third party certification.
- The use of over joist and under rafter insulation is considered best practice as it eliminates the cold bridge caused by the joist/rafter.
- The installation of the eaves insulation must not prevent free water drainage below the tiling battens.
- If compressible insulant is installed between the studs in addition to the rigid board insulant over, then it should be tightly packed and be in direct contact with the rigid board. Care must be taken to ensure that the compressible insulant is maintained above the dewpoint temperature.
- This detail to be read in conjunction with detail No: SFW-RG-02.

CHECKLIST (TICK)

**THERMAL PERFORMANCE OF JUNCTION**

- Ensure the gap between the wall plate and the proprietary eaves guard is completely filled with insulation having a min. R-value across the thickness of the insulation of 1.2 m<sup>2</sup>.K/W. ①
- Ensure continuity of the insulation throughout the junction.
- Ensure that the full depth of insulation between and under the rafters abuts the eaves insulation.
- Ensure that the insulation is installed tightly between the rafters and is in contact with the under rafter insulation. ②

*Complying with the above checklist items qualifies the builder to claim the  $\Psi$  value given in Table 3 of IP 1/06 and Table K1 of SAP 2005.*

CHECKLIST (TICK)

**AIR BARRIER CONTINUITY**

- Ensure air barrier continuity between the ceiling and the wall lining or sheathing layer. A flexible membrane installed below the wall plate may be used to provide this continuity. ③
- Seal all penetrations through air barrier using a flexible sealant or tape.

*Complying with all of the above checklist items will help achieve the design air permeability and may effect a reduced testing regime.*

OPTION (TICK)

**AIR BARRIER OPTIONS**

- Rigid insulation or board sheathing
- Internal lining (e.g. plasterboard)

The above indicative guidance illustrates good practice for the design and construction of interfaces only in respect to ensuring thermal performance and air barrier continuity. The above guidance must be implemented with due regard to all other requirements imposed by the Building Regulations.

| SITE MANAGER/ SUPERVISOR: | SITE NAME: | PLOT No: | DATE: |
|---------------------------|------------|----------|-------|
|                           |            |          |       |

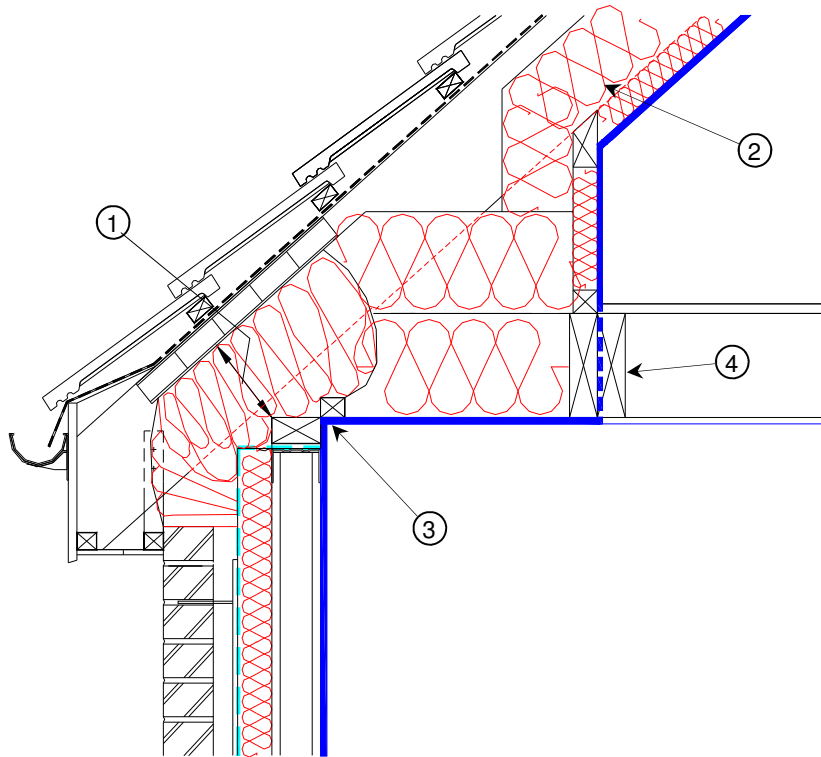

Accredited (Indicative) Detail Number: SFW-RE-05

**GENERAL NOTES**

- Use a proprietary eaves ventilator to ensure ventilation in accordance with BS5250.
- If required by BS5250 use a vapour control plasterboard or a separate vapour control layer behind the plasterboard.
- The use of over joist and under rafter insulation is considered best practice as it eliminates the cold bridge caused by the joist/rafter.
- The installation of the eaves insulation must not prevent free water drainage below the tiling battens.
- If compressible insulant is installed between the studs in addition to the rigid board insulant over, then it should be tightly packed and be in direct contact with the rigid board. Care must be taken to ensure that the compressible insulant is maintained above the dewpoint temperature.
- This detail to be read in conjunction with detail No: SFW-RG-03.

CHECKLIST (TICK)

**THERMAL PERFORMANCE OF JUNCTION**

- Ensure the gap between the wall plate and the proprietary eaves guard is completely filled with insulation having a min. R-value across the thickness of the insulation of 1.2 m<sup>2</sup>.K/W. ①
- Ensure continuity of the insulation throughout the junction.
- Ensure that the full depth of insulation between and over the joists abuts the eaves insulation.
- Ensure that the insulation is installed tightly between the rafters and is in contact with the under rafter insulation. ②

*Complying with the above checklist items qualifies the builder to claim the  $\Psi$  value given in Table 3 of IP 1/06 and Table K1 of SAP 2005.*

CHECKLIST (TICK)

**AIR BARRIER CONTINUITY**

- Ensure air barrier continuity between the ceiling and the wall lining or sheathing layer. A flexible membrane installed below the wall plate may be used to provide this continuity. ③
- Seal all penetrations through air barrier using a flexible sealant or tape.
- Install a double, full depth timber nogging between the floor joists and seal between the nogging, ceiling and upper stud wall with a flexible sealant. ④ (The dotted blue line depicts the continuity of the air barrier through the noggings)

*Complying with all of the above checklist items will help achieve the design air permeability and may effect a reduced testing regime.*

OPTION (TICK)

**AIR BARRIER OPTIONS**

- Rigid insulation or board sheathing
- Internal lining (e.g. plasterboard)

The above indicative guidance illustrates good practice for the design and construction of interfaces only in respect to ensuring thermal performance and air barrier continuity. The above guidance must be implemented with due regard to all other requirements imposed by the Building Regulations.

| SITE MANAGER/ SUPERVISOR: | SITE NAME: | PLOT No: | DATE: |
|---------------------------|------------|----------|-------|
|                           |            |          |       |

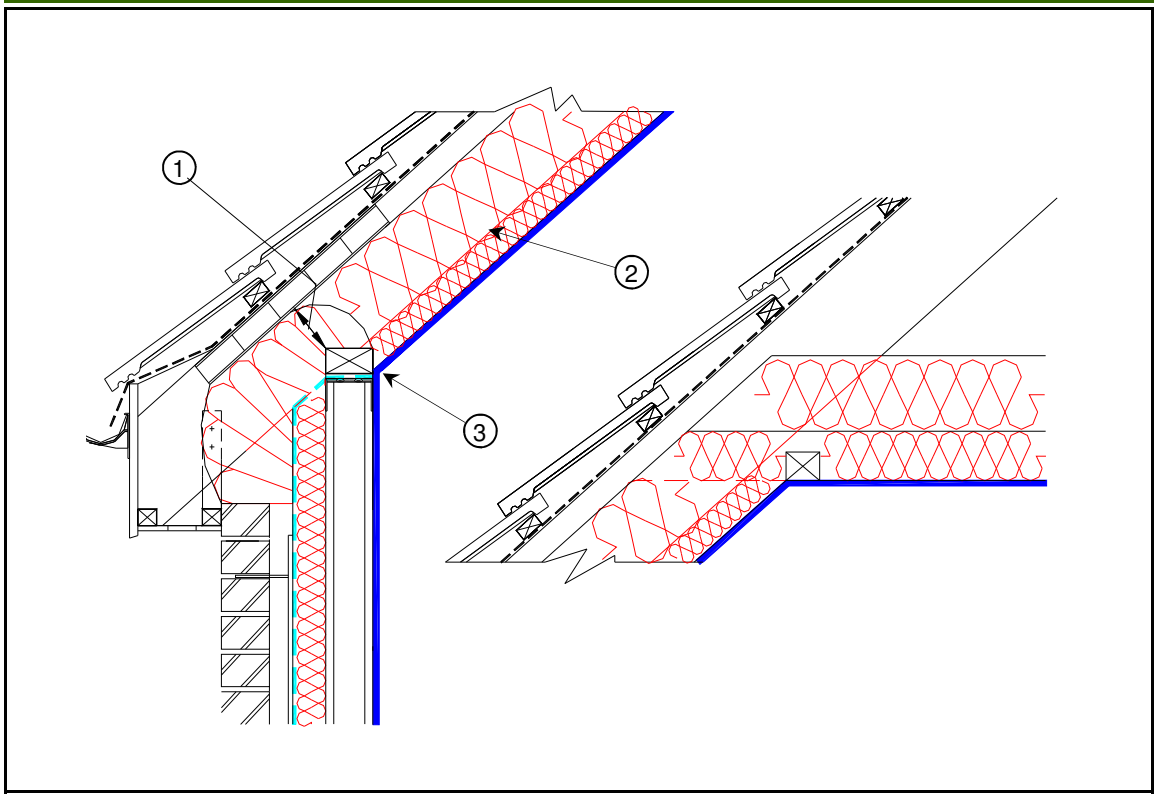

Accredited (Indicative) Detail Number: SFW-RE-06

**GENERAL NOTES**

- If required by BS5250 use a vapour control plasterboard or a separate vapour control layer behind the plasterboard.
- Use a proprietary eaves ventilator to ensure ventilation in accordance with BS5250.
- The use of over joist and under rafter insulation is considered best practice as it eliminates the cold bridge caused by the joist/rafter.
- The installation of the eaves ventilator must not prevent free water drainage below the tiling battens.
- If compressible insulant is installed between the studs in addition to the rigid board insulant over, then it should be tightly packed and be in direct contact with the rigid board. Care must be taken to ensure that the compressible insulant is maintained above the dewpoint temperature.
- This detail to be read in conjunction with detail No: SFW-RG-03.

CHECKLIST (TICK)

**THERMAL PERFORMANCE OF JUNCTION**

- Ensure the gap between the wall plate and the proprietary eaves guard is completely filled with insulation having a min. R-value across the thickness of the insulation of 1.2 m<sup>2</sup>.K/W. ①
- Ensure continuity of the insulation throughout the junction.
- Ensure that the full depth of insulation between and under the rafters abuts the eaves insulation.
- Ensure that the insulation is installed tightly between the rafters and is in contact with the under rafter insulation. ②

*Complying with the above checklist items qualifies the builder to claim the  $\Psi$  value given in Table 3 of IP 1/06 and Table K1 of SAP 2005.*

CHECKLIST (TICK)

**AIR BARRIER CONTINUITY**

- Ensure air barrier continuity between the ceiling and the wall lining or sheathing layer. A flexible membrane installed below the wall plate may be used to provide this continuity. ③
- Seal all penetrations through air barrier using a flexible sealant or tape.

*Complying with all of the above checklist items will help achieve the design air permeability and may effect a reduced testing regime.*

OPTION (TICK)

**AIR BARRIER OPTIONS**

- Rigid insulation or board sheathing, or
- Internal lining (e.g. plasterboard)

The above indicative guidance illustrates good practice for the design and construction of interfaces only in respect to ensuring thermal performance and air barrier continuity. The above guidance must be implemented with due regard to all other requirements imposed by the Building Regulations.

| SITE MANAGER/ SUPERVISOR: | SITE NAME: | PLOT No: | DATE: |
|---------------------------|------------|----------|-------|
|                           |            |          |       |

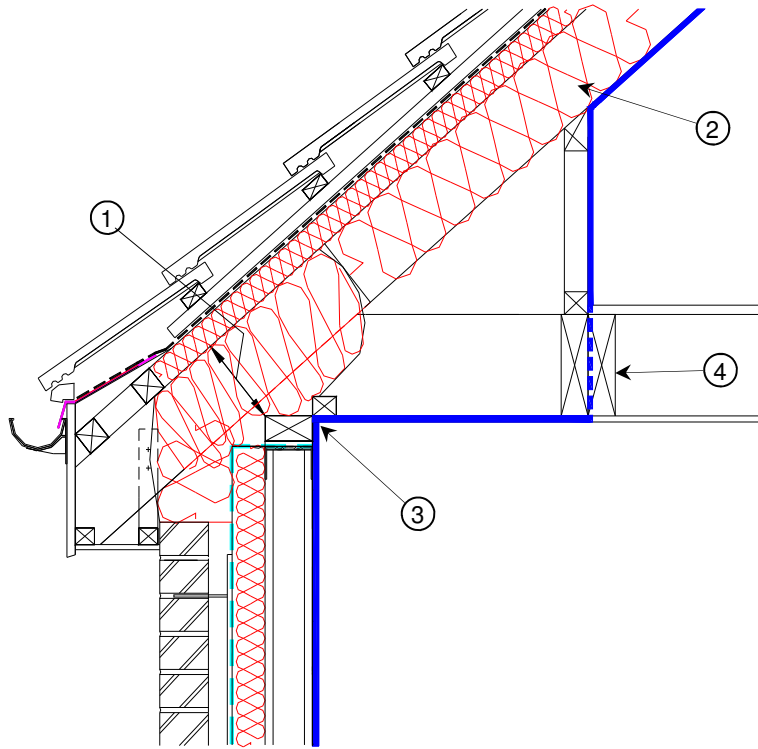

Accredited (Indicative) Detail Number: SFW-RE-07

**GENERAL NOTES**

- If required by BS5250 use a vapour control plasterboard or a separate vapour control layer behind the plasterboard.
- Vapour permeable roof underlay to be used in strict accordance with approved third party certification.
- The use of over rafter insulation is considered best practice as it eliminates the cold bridge caused by the rafter.
- If compressible insulant is installed between the studs in addition to the rigid board insulant over, then it should be tightly packed and be in direct contact with the rigid board. Care must be taken to ensure that the compressible insulant is maintained above the dewpoint temperature.
- This detail to be read in conjunction with detail No: SFW-RG-04.

CHECKLIST (TICK)

**THERMAL PERFORMANCE OF JUNCTION**

- Ensure the gap between the wall plate and the proprietary eaves guard is completely filled with insulation having a min. R-value across the thickness of the insulation of 1.2 m<sup>2</sup>.K/W. ①
- Ensure continuity of the insulation throughout the junction.
- Ensure that the full depth of insulation between and over the rafters abuts the eaves insulation.
- Ensure that the insulation is installed tightly between the rafters and is in contact with the over rafter insulation. ②

*Complying with the above checklist items qualifies the builder to claim the  $\Psi$  value given in Table 3 of IP 1/06 and Table K1 of SAP 2005.*

CHECKLIST (TICK)

**AIR BARRIER CONTINUITY**

- Ensure air barrier continuity between the ceiling and the wall lining or sheathing layer. A flexible membrane installed below the wall plate may be used to provide this continuity. ③
- Seal all penetrations through air barrier using a flexible sealant or tape.
- Install a double, full depth timber nogging between the floor joists and seal between the nogging, ceiling and upper stud wall with a flexible sealant. ④ (The dotted blue line depicts the continuity of the air barrier through the noggings)

*Complying with all of the above checklist items will help achieve the design air permeability and may effect a reduced testing regime.*

OPTION (TICK)

**AIR BARRIER OPTIONS**

- Rigid insulation or board sheathing, or
- Internal lining (e.g. plasterboard)

The above indicative guidance illustrates good practice for the design and construction of interfaces only in respect to ensuring thermal performance and air barrier continuity. The above guidance must be implemented with due regard to all other requirements imposed by the Building Regulations.

| SITE MANAGER/ SUPERVISOR: | SITE NAME: | PLOT No: | DATE: |
|---------------------------|------------|----------|-------|
|                           |            |          |       |

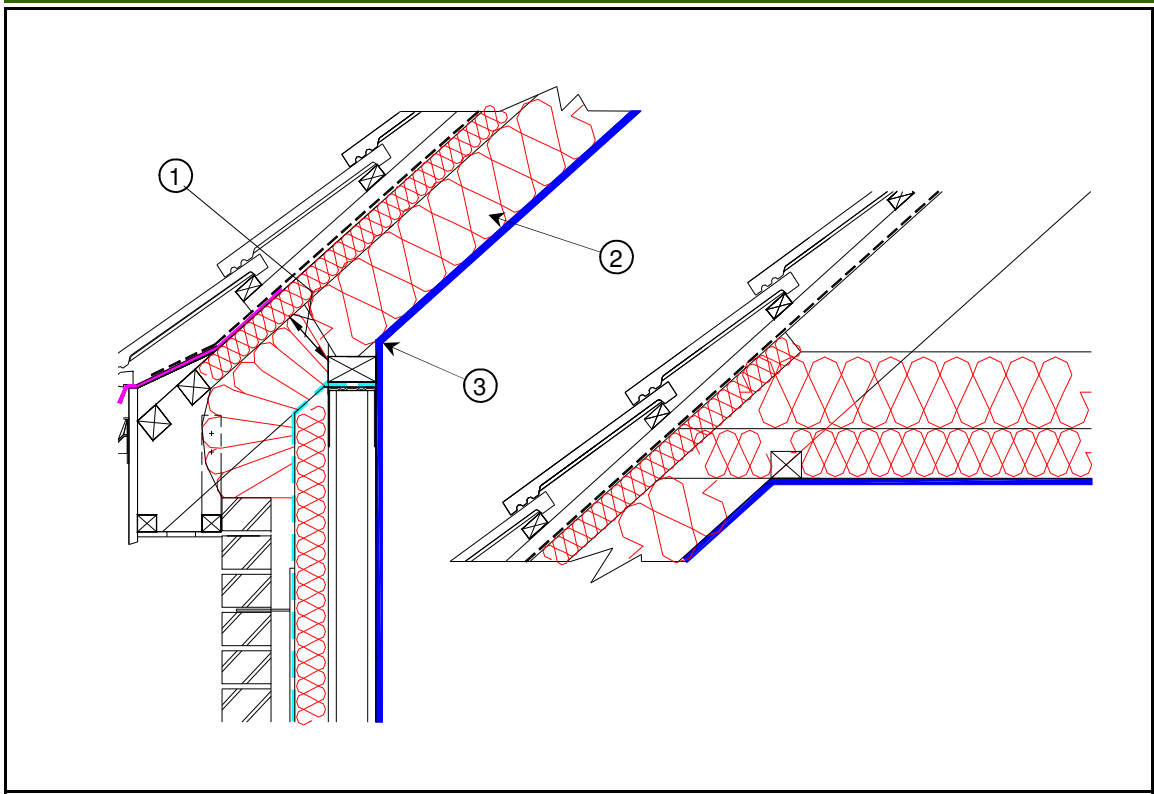

Accredited (Indicative) Detail Number: SFW-RE-08

**GENERAL NOTES**

- If required by BS5250 use a vapour control plasterboard or a separate vapour control layer behind the plasterboard.
- Vapour permeable roof underlay to be used in strict accordance with approved third party certification.
- The use of over joist insulation is considered best practice as it eliminates the cold bridge caused by the rafters.
- If compressible insulant is installed between the studs in addition to the rigid board insulant over, then it should be tightly packed and be in direct contact with the rigid board. Care must be taken to ensure that the compressible insulant is maintained above the dewpoint temperature.
- This detail to be read in conjunction with detail No: SFW-RG-04.

The above indicative guidance illustrates good practice for the design and construction of interfaces only in respect to ensuring thermal performance and air barrier continuity. The above guidance must be implemented with due regard to all other requirements imposed by the Building Regulations.

**THERMAL PERFORMANCE OF JUNCTION**

CHECKLIST (TICK)

- Ensure the gap between the wall plate and the proprietary eaves guard is completely filled with insulation having a min. R-value across the thickness of the insulation of 1.2 m<sup>2</sup>.K/W. ①
- Ensure continuity of the insulation throughout the junction.
- Ensure that the full depth of insulation between and over the rafters abuts the eaves insulation.
- Ensure that the insulation is installed tightly between the rafters and is in contact with the under rafter insulation.②

*Complying with the above checklist items qualifies the builder to claim the  $\Psi$  value given in Table 3 of IP 1/06 and Table K1 of SAP 2005.*

**AIR BARRIER CONTINUITY**

CHECKLIST (TICK)

- Ensure air barrier continuity between the ceiling and the wall lining or sheathing layer. A flexible membrane installed below the wall plate may be used to provide this continuity. ③
- Seal all penetrations through air barrier using a flexible sealant or tape.

*Complying with all of the above checklist items will help achieve the design air permeability and may effect a reduced testing regime.*

**AIR BARRIER OPTIONS**

OPTION (TICK)

- Rigid insulation or board sheathing, or
- Internal lining (e.g. plasterboard)

| SITE MANAGER/ SUPERVISOR: | SITE NAME: | PLOT No: | DATE: |
|---------------------------|------------|----------|-------|
|                           |            |          |       |

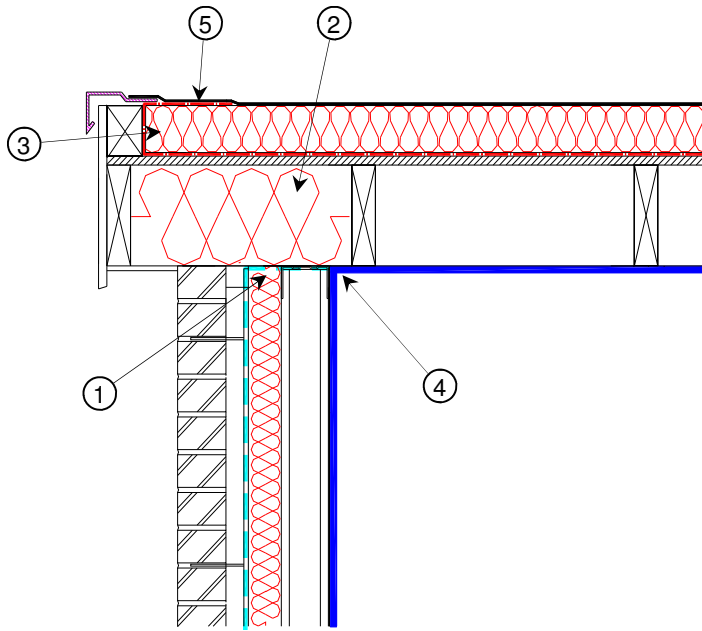

Accredited (Indicative) Detail Number: SFW-RF-01

**GENERAL NOTES**

- BS5250 requires a vapour control layer to be installed between the deck and insulation.
- Turn up vapour control layer at edge of roof insulation, lap with roof waterproofing layer, and seal. ⑤
- If compressible insulant is installed between the studs in addition to the rigid board insulant over, then it should be tightly packed and be in direct contact with the rigid board. Care must be taken to ensure that the compressible insulant is maintained above the dewpoint temperature

The above indicative guidance illustrates good practice for the design and construction of interfaces only in respect to ensuring thermal performance and air barrier continuity. The above guidance must be implemented with due regard to all other requirements imposed by the Building Regulations.

CHECKLIST (TICK)

**THERMAL PERFORMANCE OF JUNCTION**

- Ensure that the wall insulation is taken up level with top of wall. ①
- Fit the insulation over the top of the wall within the gable ladder. Fully fill the void ensuring that the insulation is installed tightly between the joists and is in contact with the roof deck. ②
- Ensure that the full depth of over roof insulation over the joists extends to the edge of the roof. ③

*Complying with the above checklist items qualifies the builder to claim the  $\Psi$  value given in Table 3 of IP 1/06 and Table K1 of SAP 2005.*

CHECKLIST (TICK)

**AIR BARRIER CONTINUITY**

- Ensure air barrier continuity between the ceiling and the wall lining or sheathing layer. A flexible membrane installed below the wall plate may be used to provide this continuity. ④
- Seal all penetrations through air barrier using a flexible sealant or tape.

*Complying with all of the above checklist items will help achieve the design air permeability and may effect a reduced testing regime.*

OPTION (TICK)

**AIR BARRIER OPTIONS**

- Rigid insulation or board sheathing
- Internal lining (e.g. plasterboard)

| SITE MANAGER/ SUPERVISOR: | SITE NAME: | PLOT No: | DATE: |
|---------------------------|------------|----------|-------|
|                           |            |          |       |

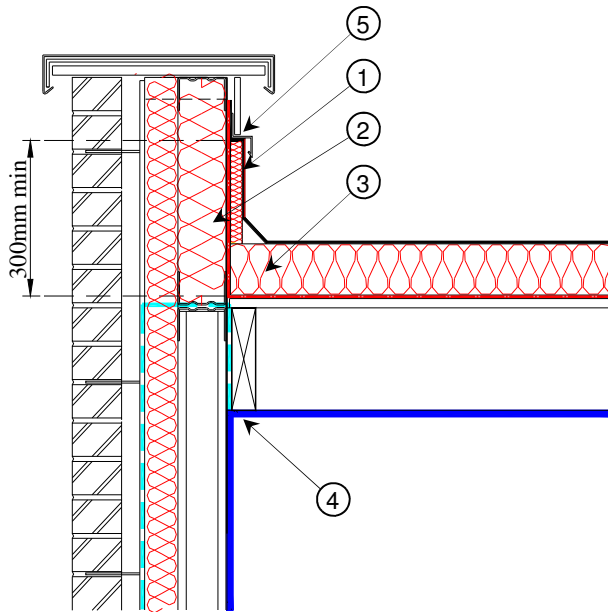

Accredited (Indicative) Detail Number: SFW-RF-02

**GENERAL NOTES**

- If required by BS5250 use a vapour control plasterboard or a separate vapour control layer behind the plasterboard.
- Turn up vapour control layer at edge of roof insulation, lap with roof waterproofing layer, and seal. ⑤
- If compressible insulant is installed between the studs in addition to the rigid board insulant over, then it should be tightly packed and be in direct contact with the rigid board. Care must be taken to ensure that the compressible insulant is maintained above the dewpoint temperature.

The above indicative guidance illustrates good practice for the design and construction of interfaces only in respect to ensuring thermal performance and air barrier continuity. The above guidance must be implemented with due regard to all other requirements imposed by the Building Regulations.

CHECKLIST (TICK)

**THERMAL PERFORMANCE OF JUNCTION**

- Install an insulation upstand having a minimum R value of 0.75m<sup>2</sup>K/W (in the heat flow direction perpendicular to the wall surface) around parapet. ①
- Install compressible insulant between the wall studs above the level of the roof deck. ②
- Maintain a minimum distance of 300 mm between the top of the insulation upstand and bottom of horizontal roof insulation.
- Ensure that the roof insulation tightly abuts the inner face of the parapet wall. ③

*Complying with the above checklist items qualifies the builder to claim the  $\Psi$  value given in Table 3 of IP 1/06 and Table K1 of SAP 2005.*

CHECKLIST (TICK)

**AIR BARRIER CONTINUITY**

- Ensure air barrier continuity between the ceiling and the wall lining or sheathing layer. A flexible membrane installed below the wall plate may be used to provide this continuity. ④
- Fully seal all penetrations through air barrier using a flexible sealant.

*Complying with all of the above checklist items will help achieve the design air permeability and may effect a reduced testing regime.*

OPTION (TICK)

**AIR BARRIER OPTIONS**

- Rigid insulation or board sheathing, or
- Internal lining (e.g. plasterboard)

| SITE MANAGER/ SUPERVISOR: | SITE NAME: | PLOT No: | DATE: |
|---------------------------|------------|----------|-------|
|                           |            |          |       |

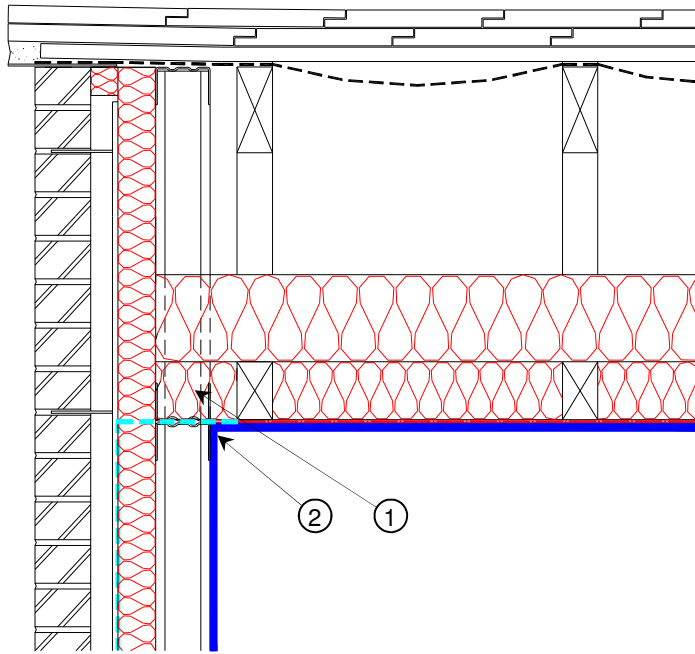

Accredited (Indicative) Detail Number: SFW-RG-01

**GENERAL NOTES**

- The use of over joist insulation is considered best practice as it eliminates the cold bridge caused by the joist.
- If compressible insulant is installed between the studs in addition to the rigid board insulant over, then it should be tightly packed and be in direct contact with the rigid board. Care must be taken to ensure that the compressible insulant is maintained above the dewpoint temperature.
- This detail to be read in conjunction with detail Nos: SFW-RE-01 & SFW-RE-02.

The above indicative guidance illustrates good practice for the design and construction of interfaces only in respect to ensuring thermal performance and air barrier continuity. The above guidance must be implemented with due regard to all other requirements imposed by the Building Regulations.

CHECKLIST (TICK)

**THERMAL PERFORMANCE OF JUNCTION**

- Pack compressible insulation between last truss/ joist and gable wall insulation. ①
- Ensure that the full depth of insulation between and over the joists extends to the inner face of the rigid wall sheathing insulant.

*Complying with the above checklist items qualifies the builder to claim the  $\Psi$  value given in Table 3 of IP 1/06 and Table K1 of SAP 2005.*

CHECKLIST (TICK)

**AIR BARRIER CONTINUITY**

- Ensure air barrier continuity between the ceiling and the wall lining or sheathing layer. A flexible membrane installed below the wall plate may be used to provide this continuity. ②
- Seal all penetrations through air barrier using a flexible sealant or tape.

*Complying with all of the above checklist items will help achieve the design air permeability and may effect a reduced testing regime.*

OPTION (TICK)

**AIR BARRIER OPTIONS**

- Rigid insulation or board sheathing
- Internal lining (e.g. plasterboard)

| SITE MANAGER/ SUPERVISOR: | SITE NAME: | PLOT No: | DATE: |
|---------------------------|------------|----------|-------|
|                           |            |          |       |

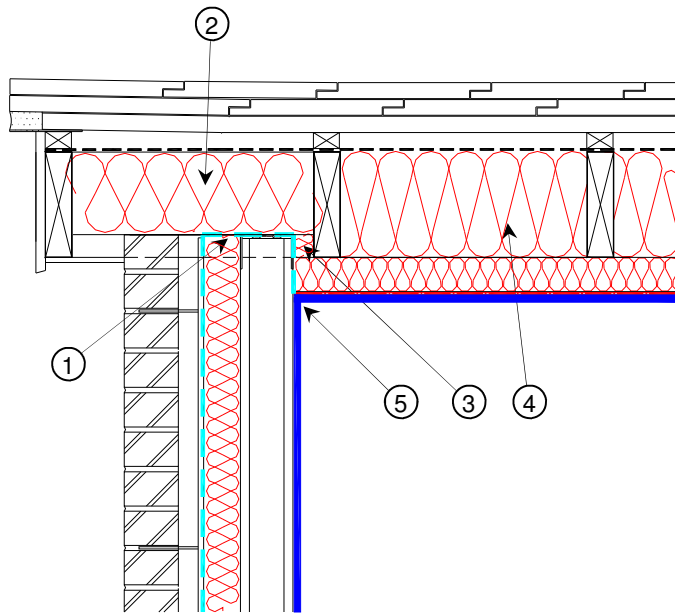

Accredited (Indicative) Detail Number: SFW-RG-02

**GENERAL NOTES**

- If required by BS5250 use a vapour control plasterboard or a separate vapour control layer behind the plasterboard.
- Vapour permeable roof underlay to be used in strict accordance with approved third party certification.
- The use of under rafter insulation is considered best practice as it eliminates the cold bridge caused by the rafter.
- If compressible insulant is installed between the studs in addition to the rigid board insulant over, then it should be tightly packed and be in direct contact with the rigid board. Care must be taken to ensure that the compressible insulant is maintained above the dewpoint temperature.
- This detail to be read in conjunction with detail No: SFW-RE-03 or SFW-RE-04.

The above indicative guidance illustrates good practice for the design and construction of interfaces only in respect to ensuring thermal performance and air barrier continuity. The above guidance must be implemented with due regard to all other requirements imposed by the Building Regulations.

CHECKLIST (TICK)

**THERMAL PERFORMANCE OF JUNCTION**

- Ensure that the wall insulation is taken up level with top of wall. ①
- Ensure continuity of the insulation throughout the junction.
- Fit the insulation over the top of the wall within the gable ladder. Fully fill the void unless the roof underlay requires to be draped when a 25mm void must be maintained. ②
- Ensure that the full depth of insulation between and under the rafters extends to the wall. Pack the gap between rafter and wall with compressible insulation. ③
- Ensure that the insulation is installed tightly between the rafters and is in contact with the under rafter insulation. ④

Complying with the above checklist items qualifies the builder to claim the  $\Psi$  value given in Table 3 of IP 1/06 and Table K1 of SAP 2005.

CHECKLIST (TICK)

**AIR BARRIER CONTINUITY**

- Ensure air barrier continuity between the ceiling and the wall lining or sheathing layer. A flexible membrane installed below the wall plate may be used to provide this continuity. ⑤
- Seal all penetrations through air barrier using a flexible sealant or tape.

Complying with all of the above checklist items will help achieve the design air permeability and may effect a reduced testing regime.

OPTION (TICK)

**AIR BARRIER OPTIONS**

- Rigid insulation or board sheathing
- Internal lining (e.g. plasterboard)

| SITE MANAGER/ SUPERVISOR: | SITE NAME: | PLOT No: | DATE: |
|---------------------------|------------|----------|-------|
|                           |            |          |       |

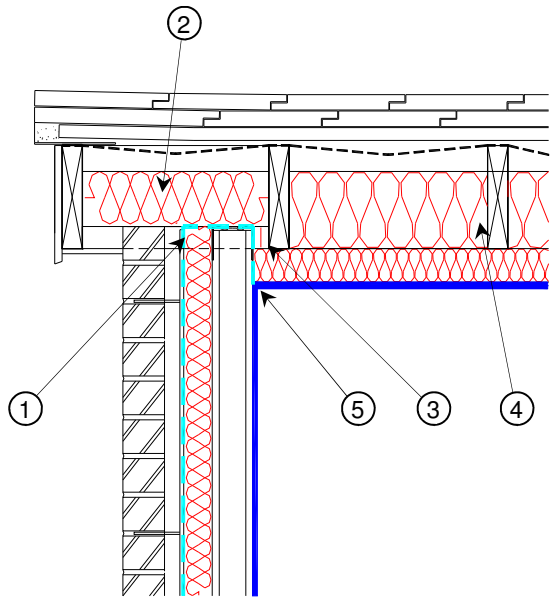

Accredited (Indicative) Detail Number: SFW-RG-03

**GENERAL NOTES**

- If required by BS5250 use a vapour control plasterboard or a separate vapour control layer behind the plasterboard.
- The use of under rafter insulation is considered best practice as it eliminates the cold bridge caused by the rafter.
- Ensure ventilation to roof build-up in accordance with BS5250.
- If compressible insulant is installed between the studs in addition to the rigid board insulant over, then it should be tightly packed and be in direct contact with the rigid board. Care must be taken to ensure that the compressible insulant is maintained above the dewpoint temperature.
- This detail to be read in conjunction with detail No: SFW-RE-05 and SFW-RE-06.

The above indicative guidance illustrates good practice for the design and construction of interfaces only in respect to ensuring thermal performance and air barrier continuity. The above guidance must be implemented with due regard to all other requirements imposed by the Building Regulations.

CHECKLIST (TICK)

**THERMAL PERFORMANCE OF JUNCTION**

- Ensure that the wall insulation is taken up level with top of wall. ①
- Ensure continuity of the insulation throughout the junction.
- Fit the insulation over the top of the wall within the gable ladder. Fully fill the void unless the roof underlay requires to be draped when a 25mm void must be maintained. ②
- Ensure that the full depth of insulation between and under the rafters extends to the wall. Pack the gap between rafter and wall with compressible insulation. ③
- Ensure that the insulation is installed tightly between the rafters and is in contact with the under rafter insulation. ④

*Complying with the above checklist items qualifies the builder to claim the  $\Psi$  value given in Table 3 of IP 1/06 and Table K1 of SAP 2005.*

CHECKLIST (TICK)

**AIR BARRIER CONTINUITY**

- Ensure air barrier continuity between the ceiling and the wall lining or sheathing layer. A flexible membrane installed below the wall plate may be used to provide this continuity. ⑤
- Seal all penetrations through air barrier using a flexible sealant or tape.

*Complying with all of the above checklist items will help achieve the design air permeability and may effect a reduced testing regime.*

OPTION (TICK)

**AIR BARRIER OPTIONS**

- Rigid insulation or board sheathing, or
- Internal lining (e.g. plasterboard)

| SITE MANAGER/ SUPERVISOR: | SITE NAME: | PLOT No: | DATE: |
|---------------------------|------------|----------|-------|
|                           |            |          |       |

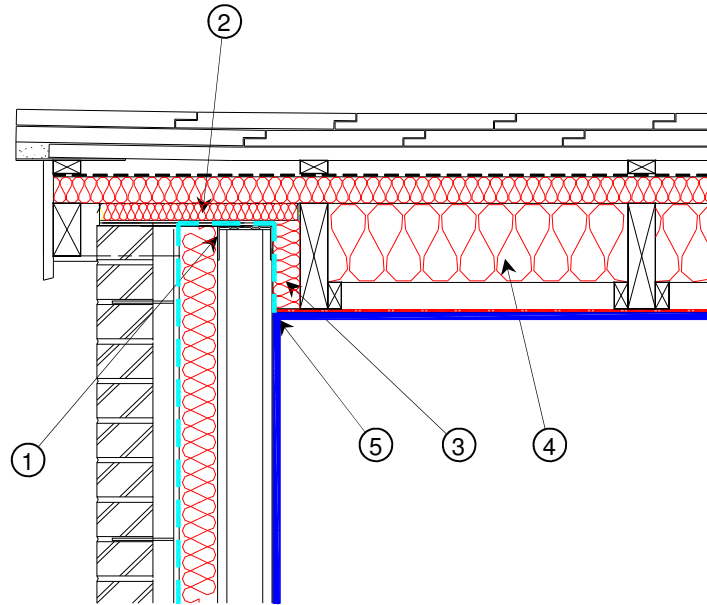

Accredited (Indicative) Detail Number: SFW-RG-04

**GENERAL NOTES**

- If required by BS5250 use a vapour control plasterboard or a separate vapour control layer behind the plasterboard.
- Vapour permeable roof underlay to be used in strict accordance with approved third party certification.
- The use of over rafter insulation is considered best practice as it eliminates the cold bridge caused by the rafter.
- If compressible insulant is installed between the studs in addition to the rigid board insulant over, then it should be tightly packed and be in direct contact with the rigid board. Care must be taken to ensure that the compressible insulant is maintained above the dewpoint temperature.
- This detail to be read in conjunction with detail No: SFW-RE-07 or SFW-RE-08.

CHECKLIST (TICK)

- Ensure that the wall insulation is taken up level with top of wall. ①
- Fit the insulation over the top of the wall within the gable ladder. Fully fill the void between the wall head and the over rafter insulation. ②
- Ensure that the full depth of insulation between and over the rafters extends to the wall. Pack the gap between rafter and wall with compressible insulation. ③
- Ensure that the insulation is installed tightly between the rafters and is in contact with the over rafter insulation. ④

**THERMAL PERFORMANCE OF JUNCTION**

*Complying with the above checklist items qualifies the builder to claim the  $\Psi$  value given in Table 3 of IP 1/06 and Table K1 of SAP 2005.*

CHECKLIST (TICK)

- Ensure air barrier continuity between the ceiling and the wall lining or sheathing layer. A flexible membrane installed below the wall plate may be used to provide this continuity. ⑤
- Seal all penetrations through air barrier using a flexible sealant or tape.

**AIR BARRIER CONTINUITY**

*Complying with all of the above checklist items will help achieve the design air permeability and may effect a reduced testing regime.*

OPTION (TICK)

- Rigid insulation or board sheathing, or
- Internal lining (e.g. plasterboard)

**AIR BARRIER OPTIONS**

The above indicative guidance illustrates good practice for the design and construction of interfaces only in respect to ensuring thermal performance and air barrier continuity. The above guidance must be implemented with due regard to all other requirements imposed by the Building Regulations.

| SITE MANAGER/ SUPERVISOR: | SITE NAME: | PLOT No: | DATE: |
|---------------------------|------------|----------|-------|
|                           |            |          |       |

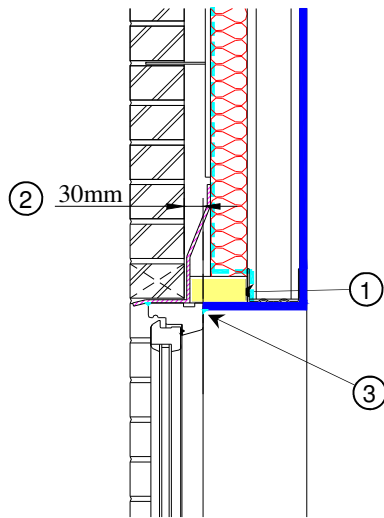

Accredited (Indicative) Detail Number: SFW-WD-01

**GENERAL NOTES**

- If compressible insulant is installed between the studs in addition to the rigid board insulant over, then it should be tightly packed and be in direct contact with the rigid board. Care must be taken to ensure that the compressible insulant is maintained above the dewpoint temperature.

The above indicative guidance illustrates good practice for the design and construction of interfaces only in respect to ensuring thermal performance and air barrier continuity. The above guidance must be implemented with due regard to all other requirements imposed by the Building Regulations.

CHECKLIST (TICK)

**THEMAL PERFORMANCE OF JUNCTION**

- Install a proprietary cavity closer or block of insulation having a path of minimum thermal resistance through the closer of not less than 0.45\_m<sup>2</sup>K/W (manufacturers certified data). ①
- Minimum frame overlap to be 30mm ②

*Complying with the above checklist items qualifies the builder to claim the  $\Psi$  value given in Table 3 of IP 1/06 and Table K1 of SAP 2005.*

CHECKLIST (TICK)

**AIR BARRIER CONTINUITY**

- Ensure air barrier continuity between the window and the wall lining or sheathing layer. A flexible membrane installed may be used to provide this continuity.
- Seal all penetrations through air barrier using a flexible sealant or tape.
- A flexible sealant should be applied to all interfaces between the wall air barrier elements and window/ door frame members. ③
- Apply external flexible seal around frame.

*Complying with all of the above checklist items will help achieve the design air permeability and may effect a reduced testing regime.*

OPTION (TICK)

**AIR BARRIER OPTIONS**

- Rigid insulation or board sheathing, or
- Internal lining (e.g. plasterboard)

| SITE MANAGER/ SUPERVISOR: | SITE NAME: | PLOT No: | DATE: |
|---------------------------|------------|----------|-------|
|                           |            |          |       |

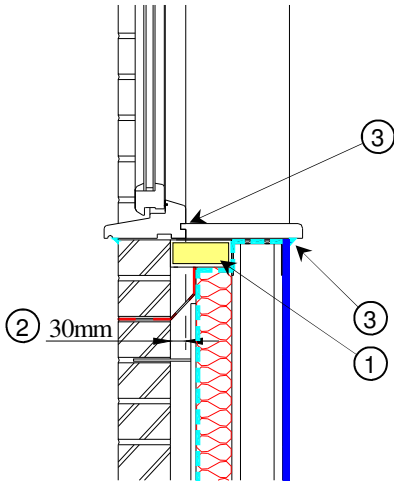

Accredited (Indicative) Detail Number: SFW-WD-02

**GENERAL NOTES**

- If compressible insulation is installed between the studs in addition to the rigid board insulation over, then it should be tightly packed and be in direct contact with the rigid board. Care must be taken to ensure that the compressible insulation is maintained above the dewpoint temperature.

The above indicative guidance illustrates good practice for the design and construction of interfaces only in respect to ensuring thermal performance and air barrier continuity. The above guidance must be implemented with due regard to all other requirements imposed by the Building Regulations.

CHECKLIST (TICK)

**THERMAL PERFORMANCE OF JUNCTION**

- Install a proprietary cavity closer having a path of minimum thermal resistance path through the closer of not less than 0.45\_m<sup>2</sup>K/W (manufacturers certified data). ①
- Minimum frame overlap to be 30mm ②

*Complying with the above checklist items qualifies the builder to claim the  $\Psi$  value given in Table 3 of IP 1/06 and Table K1 of SAP 2005.*

CHECKLIST (TICK)

**AIR BARRIER CONTINUITY**

- Ensure air barrier continuity between the window and the wall lining or sheathing layer. A flexible membrane installed may be used to provide this continuity.
- Flexible sealant should be applied to the junction between the lining and cill board and between the cill board and window frame member. ③
- Seal all penetrations through air barrier using a flexible sealant or tape.
- Apply external flexible seal around frame.

*Complying with all of the above checklist items will help achieve the design air permeability and may effect a reduced testing regime.*

OPTION (TICK)

**AIR BARRIER OPTIONS**

- Rigid insulation or board sheathing, or
- Internal lining (e.g. plasterboard)

| SITE MANAGER/ SUPERVISOR: | SITE NAME: | PLOT No: | DATE: |
|---------------------------|------------|----------|-------|
|                           |            |          |       |

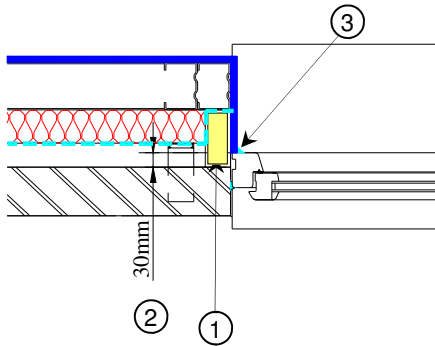

Accredited (Indicative) Detail Number: SFW-WD-03

**GENERAL NOTES**

- If compressible insulation is installed between the studs in addition to the rigid board insulation over, then it should be tightly packed and be in direct contact with the rigid board. Care must be taken to ensure that the compressible insulation is maintained above the dewpoint temperature.

The above indicative guidance illustrates good practice for the design and construction of interfaces only in respect to ensuring thermal performance and air barrier continuity. The above guidance must be implemented with due regard to all other requirements imposed by the Building Regulations.

CHECKLIST (TICK)

**THERMAL PERFORMANCE OF JUNCTION**

- Install a proprietary cavity closer having a path of minimum thermal resistance path through the closer of not less than 0.45\_m²K/W (manufacturers certified data). ①
- Minimum frame overlap to be 30mm ②

*Complying with the above checklist items qualifies the builder to claim the  $\Psi$  value given in Table 3 of IP 1/06 and Table K1 of SAP 2005.*

CHECKLIST (TICK)

**AIR BARRIER CONTINUITY**

- Ensure air barrier continuity between the window and the wall lining or sheathing layer. A flexible membrane may be used to provide this continuity.
- Flexible sealant should be applied to the junction between the lining and the window/ door frame members. ③
- Seal all penetrations through air barrier using a flexible sealant or tape.
- Apply external flexible seal around frame.

*Complying with all of the above checklist items will help achieve the design air permeability and may effect a reduced testing regime.*

OPTION (TICK)

**AIR BARRIER OPTIONS**

- Internal lining (e.g. plasterboard)
- Internal lining (e.g. plasterboard)

| SITE MANAGER/ SUPERVISOR: | SITE NAME: | PLOT No: | DATE: |
|---------------------------|------------|----------|-------|
|                           |            |          |       |

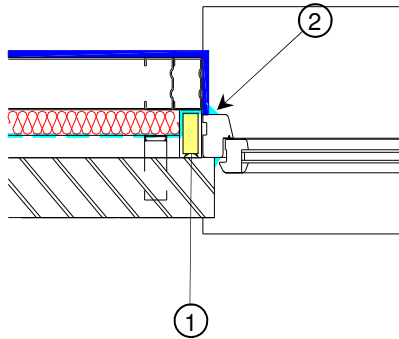

Accredited (Indicative) Detail Number: SFW-WD-04

**GENERAL NOTES**

- If compressible insulation is installed between the studs in addition to the rigid board insulation over, then it should be tightly packed and be in direct contact with the rigid board. Care must be taken to ensure that the compressible insulation is maintained above the dewpoint temperature.

The above indicative guidance illustrates good practice for the design and construction of interfaces only in respect to ensuring thermal performance and air barrier continuity. The above guidance must be implemented with due regard to all other requirements imposed by the Building Regulations.

CHECKLIST (TICK)

**THERMAL PERFORMANCE OF JUNCTION**

Install a proprietary cavity closer having a path of minimum thermal resistance path through the closer of not less than 0.45\_m<sup>2</sup>K/W (manufacturers certified data). ①

*Complying with the above checklist items qualifies the builder to claim the  $\Psi$  value given in Table 3 of IP 1/06 and Table K1 of SAP 2005.*

CHECKLIST (TICK)

**AIR BARRIER CONTINUITY**

Ensure air barrier continuity between the window and the wall lining or sheathing layer. A flexible membrane may be used to provide this continuity.

Flexible sealant should be applied to the junction between the lining and the window/ door frame members. ②

Seal all penetrations through air barrier using a flexible sealant or tape.

Apply external flexible seal around frame.

*Complying with all of the above checklist items will help achieve the design air permeability and may effect a reduced testing regime.*

OPTION (TICK)

**AIR BARRIER OPTIONS**

Rigid insulation or board sheathing, or

Internal lining (e.g. plasterboard)

| SITE MANAGER/ SUPERVISOR: | SITE NAME: | PLOT No: | DATE: |
|---------------------------|------------|----------|-------|
|                           |            |          |       |